

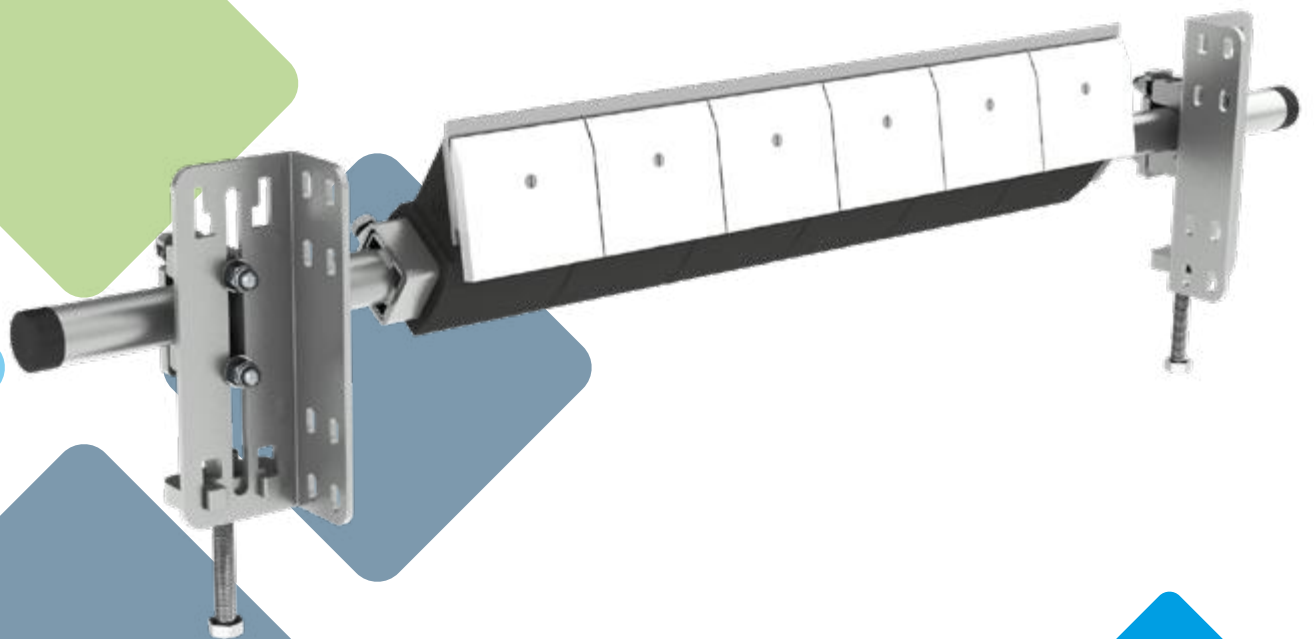

TECHNICGUM
MLT GROUP



RacloFlex 

Secondary scraper
multi-blade,
economic and polyvalent

WHY CHOOSE THE RACLOFLEX N ?

Structure protected for a long time

❖ An ingenious system that adapts

Unlike the simple single-blade scrapers, the **RacloFlex N** is comprised of blades each supported by a shock absorber block which can be adjusted independently to shape the belt and compensate the faster wear of certain blades.

Faithful to its original patented design of 1985 whilst also constantly benefiting from the latest improvements and innovations, the **RacloFlex N** is a safe value and a rational solution for conveyor belt cleaning.

Single blades cannot compensate for central wear

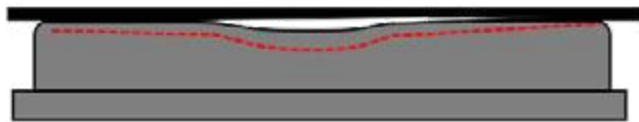

RacloFlex N can compensate for central wear

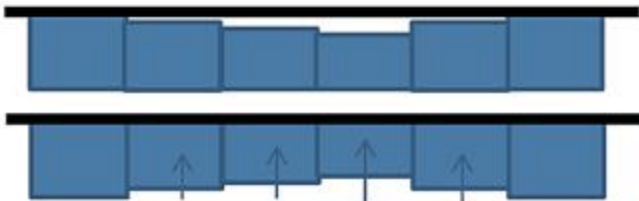

Different blades option

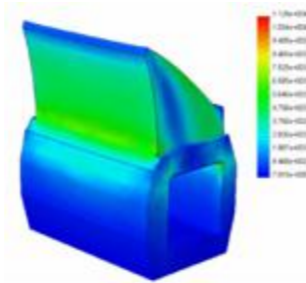

Dual-hardness



RacloFlex N and N-HD



Other scrapers

ADVANTAGES

- Economic and polyvalent
- High performance cleaning
- Galvanised metal parts
- Toothed bearing with fast opening
- Works with 2 directions of flow
- Equipped with PE-UHMW deflector
- Dual hardness rubber technology
- Adaptable on concave or convex belts
- Many types of blades available
- Realignment of the blades by central wear compensation
- Stronger than most of the equivalent models
- Only the used blades are to be replaced
- Retractable pressurization rod
- Efficiency globally proven since 1985

❖ OPTIONS, ACCESSORIES AND VERSIONS



Pulling pressure

Allows pressurization of scraper from above and within the angle.



Special «MultiTool key»

Gathers all the necessary functions for the manipulation and settings of the scraper.

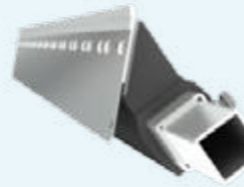

Stainless steel Deflector

Enables the earthing of the blades (ATEX) and prevents inclusion between the blocks.

❖ General information for the RacloFlex N

Quality of blade(s) :	Tungsten Carbide : 93 HRA 3x10mm Or- Tungsten Carbide : 93 HRA 5x10mm Or- Impact Carbide : 66 HRA 5x10mm <i>(Compatible with SUPER-SCREW® / ISC® / FIX'N GO®)</i> Or- Ceramic : Alumine frittée Al2O3 92% 10x15mm Or- Stainless steel (316L/304L at choice)
Working position :	Scraping angle = 90° (see notice)
Surface treatment :	All electro-galvanized steel pieces + stainless A2 bolts
Temperature :	0° / + 50° C
Scale of pH :	4 to 10
Maximum speed :	N 1 way = 3 m/s 2 ways = 2,5 m/s N -HD 1 way = 5 m/s 2 ways = 3,5 m/s
Do not expose to :	Impact and staples on tungsten carbide and ceramic (choose stainless blades or impact carbide) Oils, grease or hydrocarbide : Special quality available Corrosive atmosphere : Stainless possible on all or part Uncontrolled clogging on entire scraper

Belt, mm	400	500	650	800	1001	1002	1200	1401	1402	1600	1801	1802	2001	2002
Scraping width, mm	378	504	630	756	882	1008	1134	1260	1386	1512	1638	1764	1890	2016
Number of blades	3	4	5	6	7	8	9	10	11	12	13	14	15	16

RacloFlex N-HD

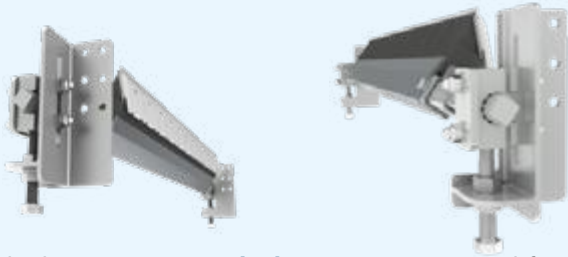

The heavy version **RacloFlex N-HD** is proposed for belts from 1400 to 2200 ; Tungsten carbide 5x10, aluminium profil block support and reinforced mechanic.

Combined use with the scraper RacloFlex NT

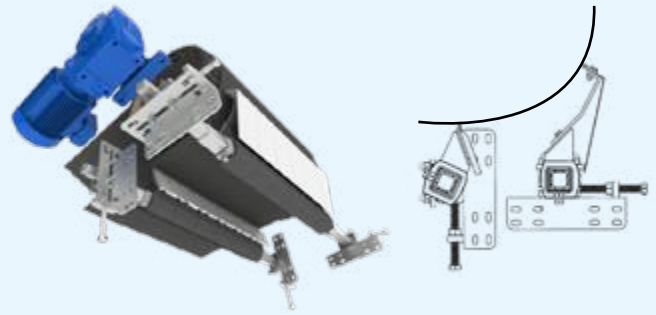

GeminiSkirt

BigBen 3

RacloFlex VP

CeraGum

GlideBar

SealBloc

Atlas

StarTracker

StarTracker

RacloFlex Z

RacloFlex SW



Logo distributor



www.mltgroup-conveyor.com - info@mltgroup-conveyor.com